

2 BUSINESS PARKWAY

Lugoff, SC, 29078

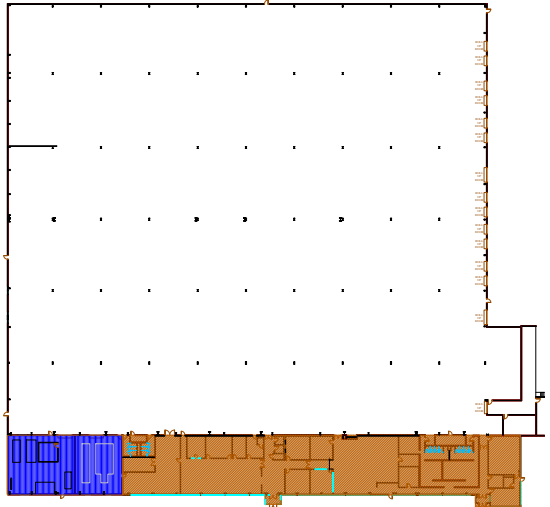
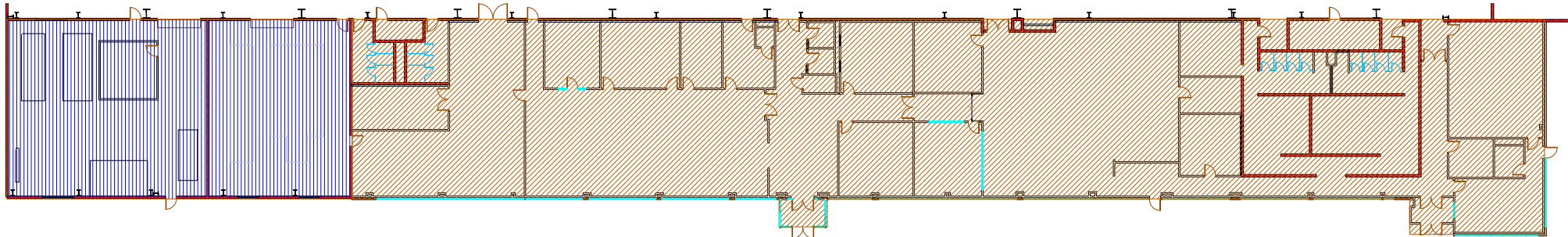
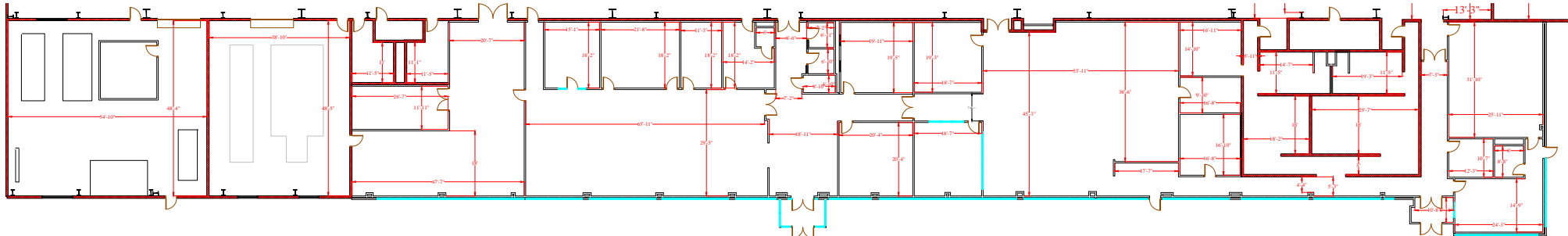
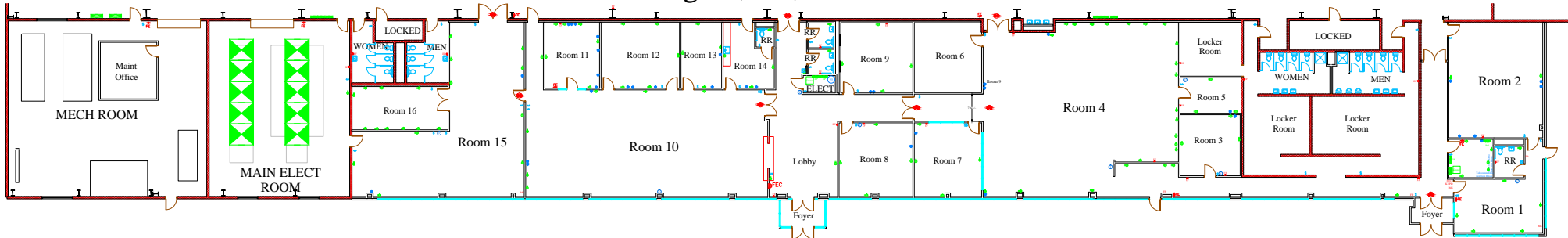

Published on Friday, October 03, 2014 1:08:45 PM - FILE NAME - 2_Business_Parkway_10032014.dwg

Prepared by
DSQUARED CONSULTING INC.
 1432 D Avenue
 West Columbia, SC, 29169
 t-803-622-9037
 f-877-651-9982
 www.dsquaredconsulting.com



These drawings are provided solely for graphic representation purposes. DSquared Consulting shall not be held liable for any and all misstatements of facts, errors or omissions, prior sale, change of price or withdrawal from the market without notice, or damages connected with use of this information. Recipient acknowledges that acceptance of these files effectively transfers any and all responsibility to recipient for use of this information. ALL INFORMATION/DIMENSIONS SHOULD BE FIELD VERIFIED.



Leasing by
Colliers INTERNATIONAL
 1301 Gervais St, Suite 600
 Columbia, SC, 29201
 803-254-2300

2 BUSINESS PARKWAY

Lugoff, SC, 29078

Leasing by



1301 Gervais St, Suite 600
Columbia, SC, 29201
803-254-2300

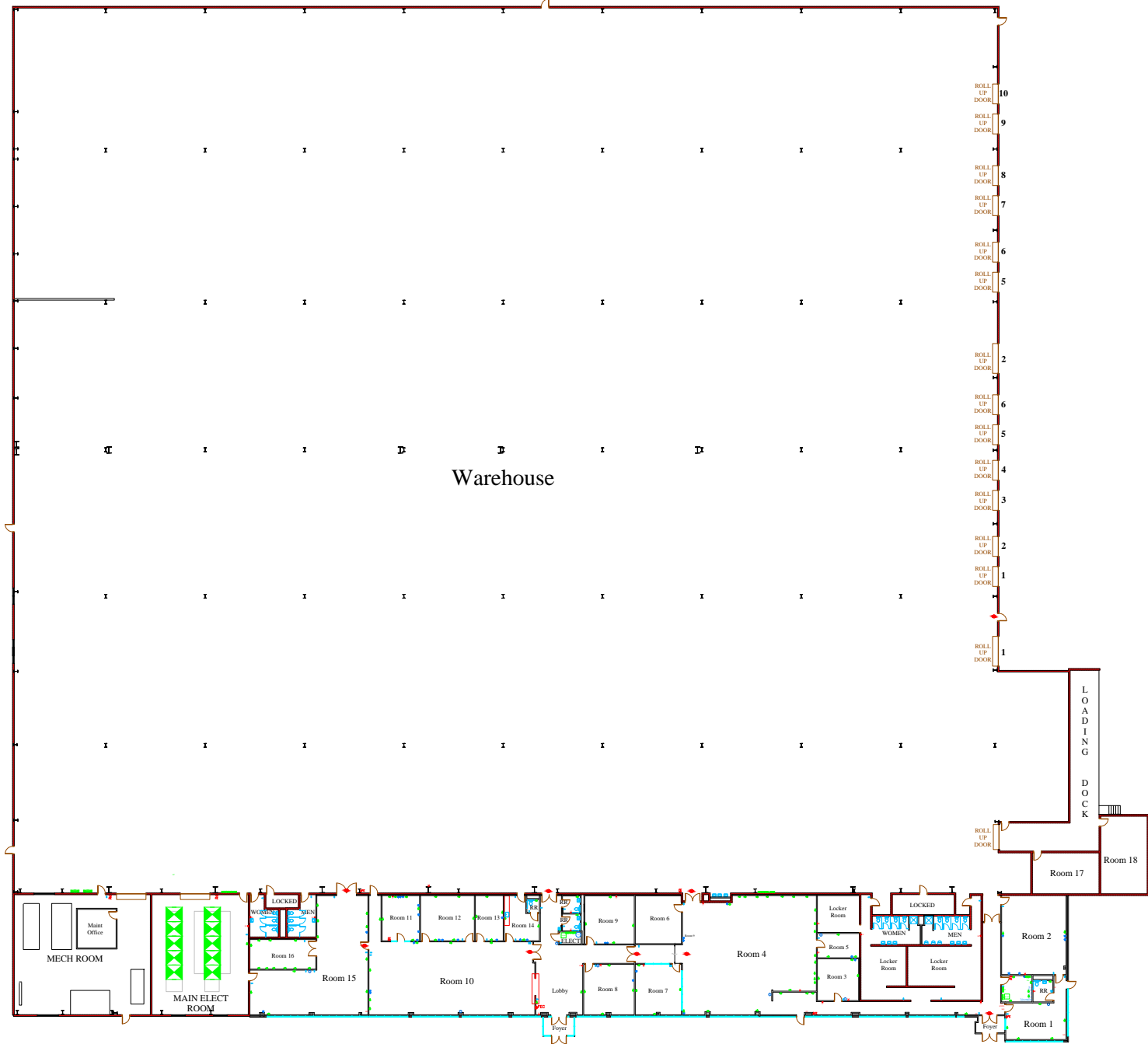

Published on Friday, October 03, 2014 1:08:49 PM - FILE NAME - 2_Business_Parkway_10032014.dwg

Prepared by
DSQUARED CONSULTING INC.
1432 D Avenue
West Columbia, SC, 29169
t-803-622-9037
f-877-651-9982
www.dsquaredconsulting.com



These drawings are provided solely for graphic representation purposes. DSquared Consulting shall not be held liable for any and all misstatements of facts, errors or omissions, prior sale, change of price or withdrawal from the market without notice, or damages connected with use of this information. Recipient acknowledges that acceptance of these files effectively transfers any and all responsibility to recipient for use of this information. ALL INFORMATION/DIMENSIONS SHOULD BE FIELD VERIFIED.

2 BUSINESS PARKWAY

Lugoff, SC, 29078

Leasing by



1301 Gervais St, Suite 600
Columbia, SC, 29201
803-254-2300

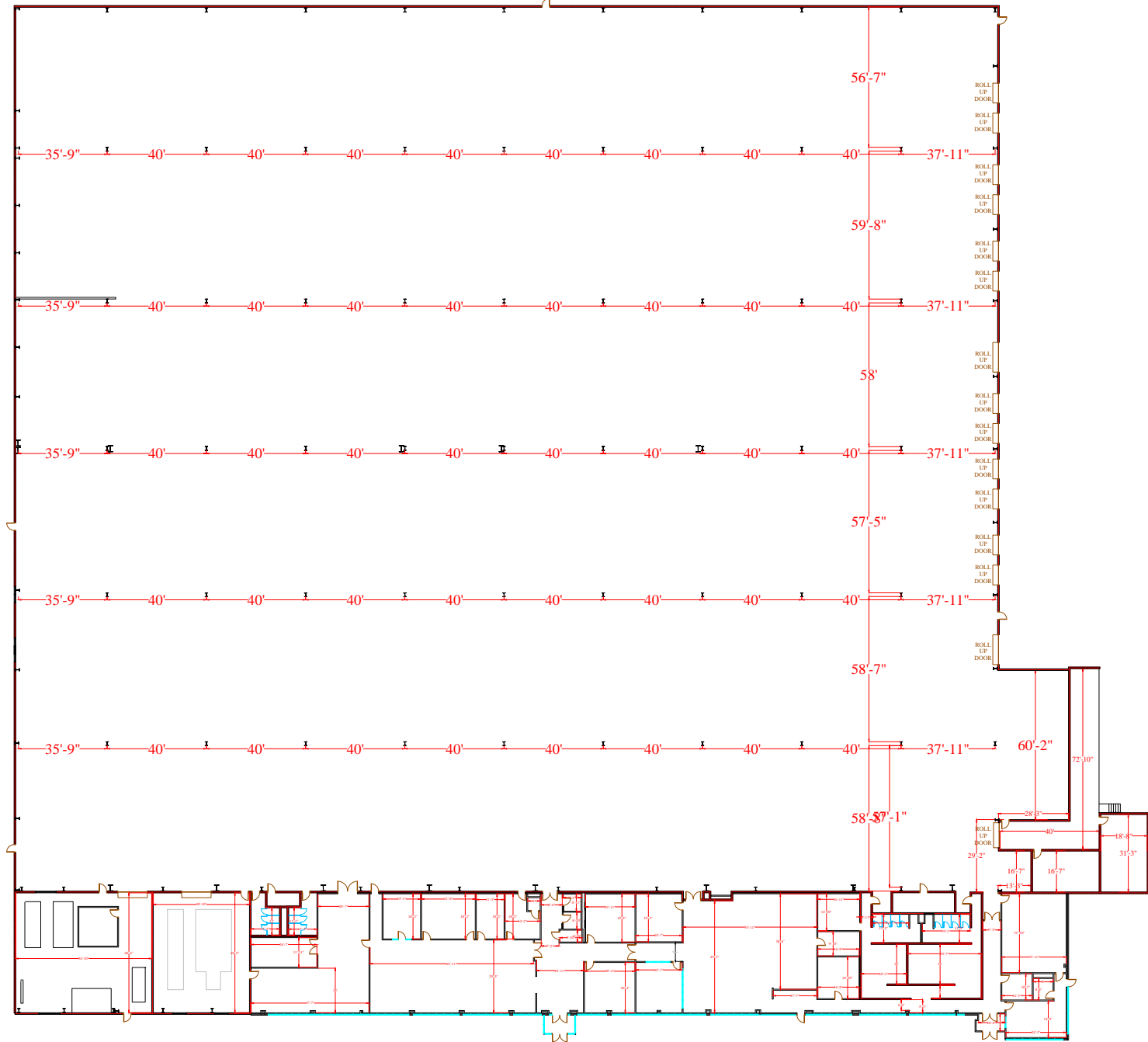

Published on Friday, October 03, 2014 1:08:54 PM - FILE NAME - 2_Business_Parkway_10032014.dwg

Prepared by
DSQUARED CONSULTING INC.
1432 D Avenue
West Columbia, SC, 29169
t-803-622-9037
f-877-651-9982
www.dsquaredconsulting.com



These drawings are provided solely for graphic representation purposes. DSquared Consulting shall not be held liable for any and all misstatements of facts, errors or omissions, prior sale, change of price or withdrawal from the market without notice, or damages connected with use of this information. Recipient acknowledges that acceptance of these files effectively transfers any and all responsibility to recipient for use of this information. ALL INFORMATION/DIMENSIONS SHOULD BE FIELD VERIFIED.

2 BUSINESS PARKWAY

Lugoff, SC, 29078

Leasing by



1301 Gervais St, Suite 600
Columbia, SC, 29201
803-254-2300

Space Assessment	
Space Description	Area
OFFICE AREA	16790
MAIN ELECTRICAL AND MECH ROOMS	4731
WAREHOUSE AREA	146479
	168000

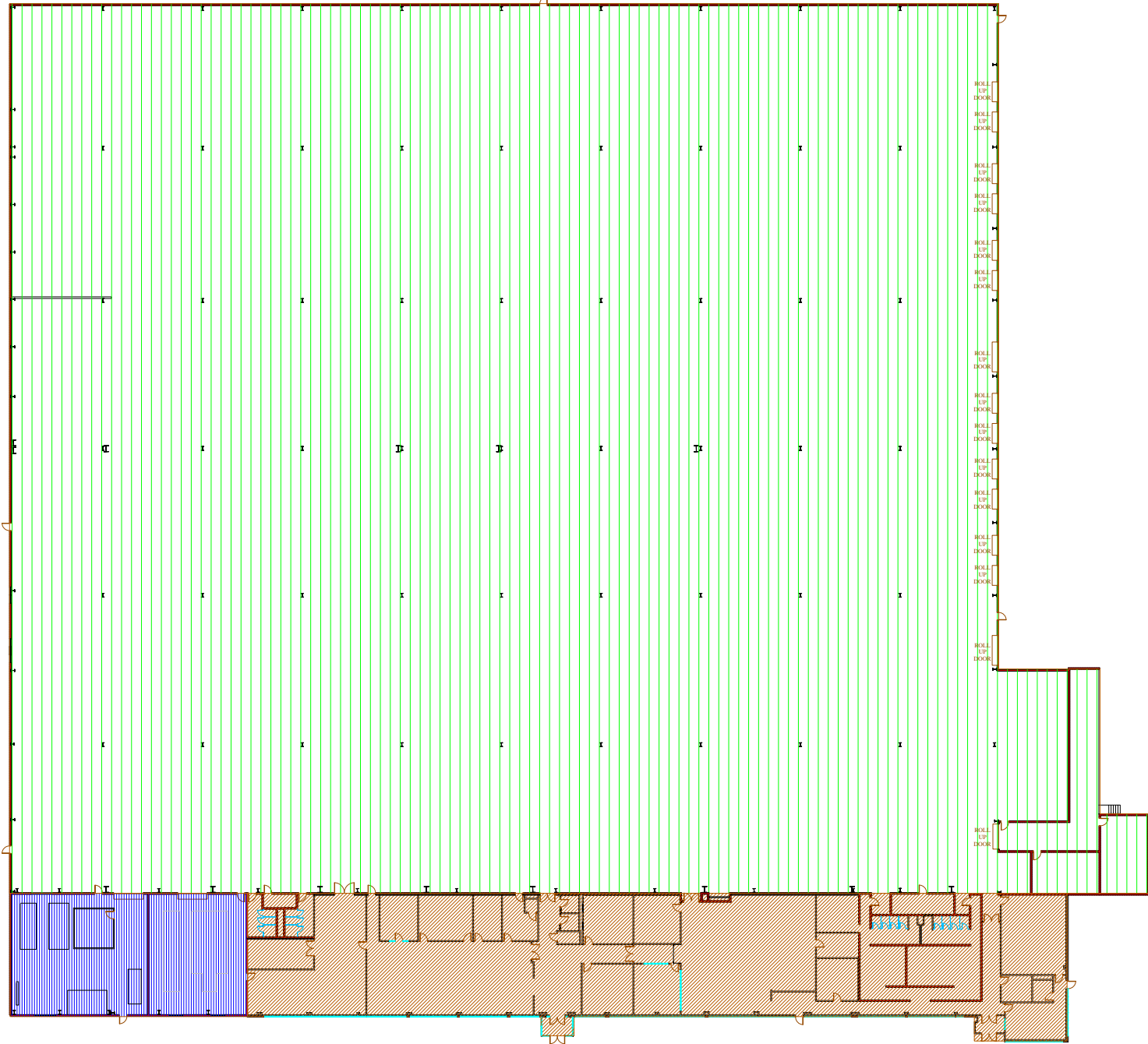

Published on Friday, October 03, 2014 1:08:57 PM - FILE NAME - 2_Business_Parkway_10032014.dwg

Prepared by
DSQUARED CONSULTING INC.
1432 D Avenue
West Columbia, SC, 29169
t-803-622-9037
f-877-651-9982
www.dsquaredconsulting.com



These drawings are provided solely for graphic representation purposes. DSquared Consulting shall not be held liable for any and all misstatements of facts, errors or omissions, prior sale, change of price or withdrawal from the market without notice, or damages connected with use of this information. Recipient acknowledges that acceptance of these files effectively transfers any and all responsibility to recipient for use of this information. ALL INFORMATION/DIMENSIONS SHOULD BE FIELD VERIFIED.